



Grant DuoWave Plus System

Triple Coil Solar Cylinder Range

Installation & User Instructions



Part No. IRL 21. Rev 00. June 2011

Do not fit on a well or borehole supply

Contents

1	Introduction & General Requirements	3	5	Electrical Installation	10
1.1	Installation Requirements	3	5.1	Immersion Heater	10
1.2	Location	3	5.2	Immersion Heater Wiring Instructions	10
1.3	Storage and Handling	3	5.3	Y-plan System	11
1.4	About Your New Cylinder	3	5.4	S-plan System	12
1.5	Open Vented Hot Water Systems	3	5.5	Solar Thermal System	13
1.6	Pipework Connections	3			
1.7	Scaling	3	6	Commissioning, Draining Down & Safety	14
1.8	Insulation	3	6.1	Filling the Cylinder	14
1.9	Health and Safety	3	6.2	Draining Down	14
			6.3	Safety Cut-Out	14
2	Technical Specifications	4	6.4	Hot Water Discharge from Tundish	14
2.1	Technical data	4	6.5	Customer Handover	14
2.2	Dimensions	5			
2.3	Connections and Controls	6	7	Maintenance	15
			7.1	Servicing & Maintenance	15
3	Primary Circuit Installation	7			
3.1	Grant DuoWave Plus Cylinders	7	8	Fault Finding	16
3.2	Boiler Primary Connections	7	8.1	Intermittent Water Discharge	16
3.3	Auxiliary Primary Connections	7	8.2	Constant Water Discharge	17
3.4	Hard Water Areas	7	8.3	No Flow from Hot water Taps	18
			8.4	Cold Water Flow from Hot Water Taps	19
4	Secondary Circuit Installation	8	8.5	Excessive Hot Water from Taps	20
4.1	Discharge Pipe Arrangement	8			
4.2	Discharge Pipe Sizing	8	9	User Instructions	21
4.3	Worked Example	8	9.1	User Instructions	21
4.4	DuoWave Plus 300	9			
4.5	Cold Water Storage Cistern (CWSC)	9	10	Warranty	22
4.6	Cold Feed Pipe	9	10.1	The Grant Cylinder Warranty	22
4.7	Open Vent Pipe	9			
4.8	Primary Connections	9		Notes	23

1 Introduction & General Requirements

1.1 Installation Requirements

Thank you for purchasing a Grant vented hot water storage cylinder from our stainless steel cylinder range. This installation manual must be read carefully before you begin installing the cylinder.

It is vitally important that you have the correct cylinder to suit your application and fully read and understand the instructions applicable to that type of installation. If you are in any doubt, stop and contact the Grant Technical helpline for assistance.

This cylinder must be installed by a competent person in compliance with all current legislation, codes of practice and local by-laws covering the installation of an open vented hot water cylinder, as applicable. Please also make sure that any installation complies with the instructions contained in this installation instruction manual.

1.2 Location

The unit is designed to be floor standing, vertically mounted, indoors, in a frost-free environment. When choosing a suitable location for the cylinder, consideration should be given to the routing of the discharge pipe to a convenient point and also the availability of an adequate power supply for connecting the immersion heater.

The cylinder may stand on any flat and level surface without any special foundation preparations, provided that it is sufficiently robust to support the full weight of the cylinder. (Refer to Technical specifications for weights).

The position of the cylinder should be such that easy access is provided for servicing the controls and replacing the immersion heater should the need arise. Generally, pipe runs should be made as short as possible and lagged to prevent heat loss.

1.3 Storage and Handling

If the cylinder is not being installed immediately, it should remain in its carton to prevent damage. We recommend that the cylinder be transported to its installation position on a sack truck or similar whilst still within the carton.

1.4 About Your New Cylinder

The DuoWave Plus cylinder has three coils for connection to Primary heat sources and is available as an Open Vented hot water system application only.

This version is supplied fitted with a single 3kW electric immersion heater.

Refer to page 10 for further details on immersion heaters.

The central heating primary from a 'conventional' boiler should be connected to the top 22mm coil, via the compression connections provided. The bottom coil should be used for the Solar Thermal. A Solid Fuel appliance should be connected to the middle coil, via the 28mm compression connections provided. Please refer to the appliance manufacturers installation instructions for more information.

1.5 Open Vented Hot Water Systems

The cylinder is used as part of an Open Vented hot water system, i.e. fed from a cold water storage cistern and fitted with an open vent pipe. The maximum head must not exceed 30m.

On no account should any type of valve be fitted where it would shut off the boiler from any means of expansion for the system.

Note: The Temperature and Pressure relief (T&P) valve **should** be left connected to the cylinder (as supplied). As it may still operate due to temperature it should be connected in the correct manner – refer to guidance given in Section 4 of these Instructions.

1.6 Pipework Connections

All Pipework connections to the cylinder **must** be made in accordance with Figure 2-2.

1.7 Scaling

In hard water areas scaling will form inside the cylinder and this will reduce both the performance and working life of the cylinder. Where the total hardness exceeds 125ppm a high capacity water softener, or suitable water conditioner, should be installed in the incoming cold water supply to the cylinder.

It is recommended that the water temperature control thermostats (on the immersion heaters and dual thermostats) fitted to the cylinder be set no higher than 60°C to minimise scale build up.

1.8 Insulation

All Grant Cylinders are insulated with 40mm thick CFC/HFC free, fire retardant, polyurethane foam injected between the stainless steel cylinder and the outer casing. This polyurethane foam has a Global Warming Potential (GWP) of less than 3 and an Ozone Depletion Potential (ODP) of 0.

1.9 Health and Safety

The information supplied in the table in Section 2 Technical Specification will help you assess the safest way to manoeuvre your cylinder into position. Please use the table to find the empty weight of your cylinder and then consider how you can safely move it into its final position.

Please leave this manual with the householder after installation.

2 Technical Specifications

2.1 Technical Data

	DuoWave Plus
Model Number	300
Storage capacity (litres)	300
Overall diameter (mm)	580
Overall height (mm)	1745
Weight empty (kg)	57
Weight when full (kg)	357
Secondary return connection (mm)	22
Cold feed/hot draw-off connections (mm)	22
Top/bottom coil connections (mm)	22
Top/bottom coil pipe diameter (mm)	22
Middle coil connections (mm)	28
Middle coil pipe diameter (mm)	28
Top coil length (m)	5.84
Top coil surface area (m ²)	0.52
Middle coil length (m)	5.70
Middle coil surface area (m ²)	0.52
Bottom (solar) coil length (m)	8.01
Bottom (solar) coil surface area (m ²)	1.14
Dedicated solar volume Vs (litres)	150
Maximum water supply pressure (bar)	3
Temp & pressure relief valve lift pressure (bar)	7
Temp & pressure relief valve lift temperature (°C)	90
Maximum primary circuit working pressure (bar)	3
Performance:	
Top coil rating (kW)	11.6
Top coil recovery rate (mins)*	26
Middle coil rating (kW)	8.5
Bottom coil rating (kW)	16.0
Standing heat loss (kW)**	2.71
Check list:	
Cylinder assembly 300 litre	1
Temp & pressure relief valve (7 bar 90°C) factory-fitted	1
Tundish 15/22mm	1
Drain cock (1/2" end feed)	1
Dual thermostat (Control 25-65°C High limit 90°C)	2
Immersion heater 3 kW (1 ³ / ₄ " boss) factory-fitted	1

* Recovery rate is based on 82°C flow @0.2 l/s over a 50°C temperature rise for 75% of contents.

** Test carried out at 60°C.

2.2 Dimensions

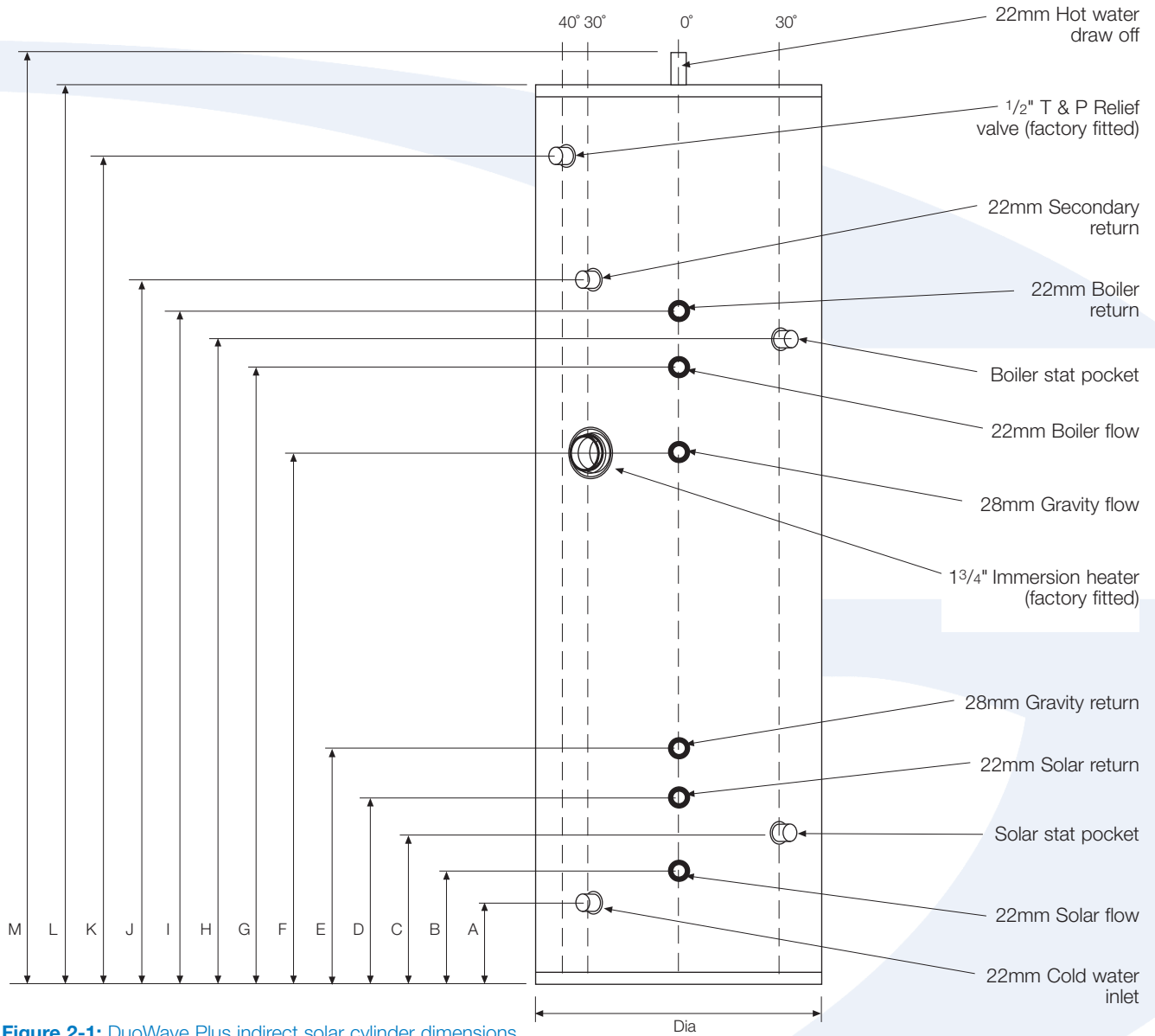

Figure 2-1: DuoWave Plus indirect solar cylinder dimensions

DuoWave Plus Indirect Cylinder Dimensions

Dims (mm)	Model 300	Dims (mm)	Model 300
A	210	H	1160
B	260	I	1210
C	325	J	1225
D	390	K	1470
E	470	L	1695
F	970	M	1745
G	1110	Dia	580

2 Technical Specifications

2.3 Connections and Controls

DuoWave Plus Open Vented Cylinder Details

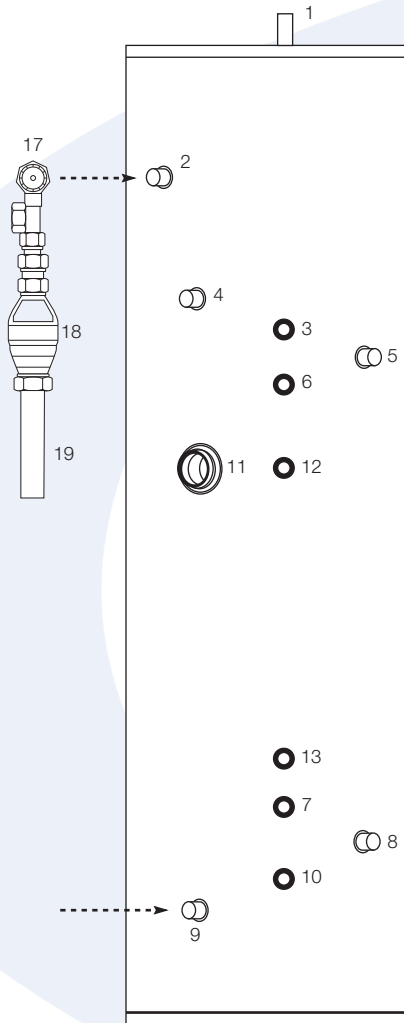

Item	Description	Connection Size
1	DHW Out	22mm compression
2	T & P valve connection	1/2" BSPF
3	Boiler return tapping	22mm compression
4	Secondary return tapping	22mm compression
5	Boiler dual thermostat pocket	-
6	Boiler flow tapping	22mm compression
7	Solar heat source return tapping	22mm compression
8	Solar heat source dual stat pocket (for dual stat only)	-
9	Cold water inlet	22mm compression
10	Solar heat source flow tapping	22mm compression
11	Immersion heater c/w control & limit thermostat (factory-fitted)	1 3/4" BSPF
12	Solid fuel (uncontrolled) flow tapping	28mm compression
13	Solid fuel (uncontrolled) return tapping	28mm compression
17	Temperature & Pressure relief valve - 90°C/7 bar	15mm compression
18	Tundish	15/22mm compression
19	Discharge pipe (not supplied with cylinder)	-
20	Mains water supply pipe (not supplied with cylinder)	-
21	Drain cock (supplied with cylinder)	-

Note:

Pipework between items 17 and 18 not supplied with cylinder.

Figure 2-2: Cylinder connections and controls

3 Primary Circuit Installation

3.1 Grant DuoWave Plus Solar Cylinders

Grant DuoWave Plus Solar cylinders are suitable for connecting to most fully pumped domestic gas or oil fired central heating boilers working on an open vented or sealed system having a maximum working pressure of 3 bar and a maximum working temperature of 90° C. **If you are in any doubt concerning the suitability of the boiler, consult the boiler manufacturer.**

3.2 Boiler Primary Connections

Central Heating

1. The boiler primary flow and return connections should be made to the top coil connections. The primary flow and return fittings are 22mm compression. The valve has 22mm compression connections.
2. Locate the dual thermostat in the stainless steel pocket (refer to Figure 2-2 for location) and secure using the retaining screws on the thermostat housing.
3. Any automatic or manual air vent fitted to vent air from the upper coil should be installed on the primary flow pipe to the coil.

3.3 Auxiliary Primary Connections

Solar Heating

The Solar flow and return connections should be made to the bottom 22mm coil connections. Refer to Figure 5-8.

Other Heat Sources

A third primary heat source should be connected to the middle coil using the 28mm compression connections. Please refer to the installation manual for that appliance.

IMPORTANT. This diagram is shown as an illustration of this type of system only. Reference must be made to the appliance manufacturers own instructions for detailed guidance on the installation of any uncontrolled appliance.

3.4 Hard Water Areas

If the cylinder is to be used in a hard water area, we recommend that the primary flow temperature be limited to 75° C. This will help reduce the migration of suspended solids in the water and help prevent the build up of lime scale.

4 Secondary Circuit Installation

4.1 Discharge Pipe Arrangement

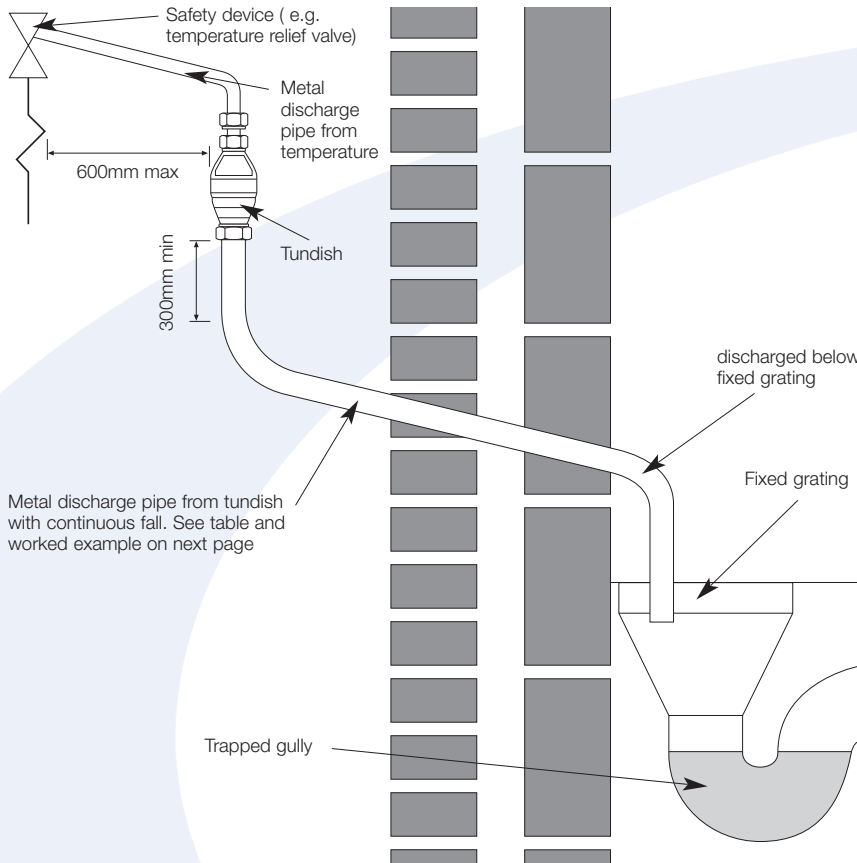

Figure 4-1: Typical discharge pipe arrangement

4.2 Discharge Pipe Sizing

Valve outlet size, diameter (inches)	Minimum size of discharge pipe D1 (mm)	Minimum size of discharge pipe D2 from tundish in (mm)	Max resistance allowed, expressed as a length of straight pipe, i.e. no elbows or bends	Resistance created by each elbow or bend in (m)
1/2	15	22	Up to 9	0.8
		28	Up to 18	1.0
		35	Up to 27	1.4
3/4	22	28	Up to 9	1.0
		35	Up to 18	1.4
		42	Up to 27	1.7
1	28	35	Up to 9	1.4
		42	Up to 18	1.7
		54	Up to 27	2.3

4.3 Worked Example

The example below is for a 1/2" diameter temperature relief valve with a discharge pipe (D2) having 4 elbows and a length of 7 m from the tundish to the point of discharge.

From

Maximum resistance allowed for a straight length of Ø22mm copper discharge pipe (D2) from a 1/2" diameter temperature relief valve is - 9.0m.

Subtract the resistance for quantity of 4 Ø22mm elbows at 0.8m each = 3.2m. Therefore, the maximum permitted length equates to 5.8m.

5.8m is less than the actual length of 7m; therefore calculate the next largest size.

Maximum resistance allowed for a straight length of Ø28mm-pipe (D2) from a 1/2" diameter temperature relief valve equates to - 18m.

Subtract the resistance for a quantity of 4 Ø28mm elbows at 1.0 each = 4m.

Therefore the maximum permitted length equates to 14m.

As the actual length is 7m, a Ø28mm diameter copper pipe will be satisfactory.

4.4 DuoWave Plus 300

The Grant DuoWave Plus 300 Open Vented Indirect Solar cylinder is designed to be used as part of a static Open Vented hot water system. It should be installed in accordance with BS6700:2006, The Building Regulations Part L and also the relevant Water Regulations – i.e. the Water Supply (Water Fittings) Regulations 1999 or the Water Byelaws 2000, Scotland.

Important: This open vented version of the DuoWave Plus MUST be used if an 'uncontrolled' heat source such as a solid fuel or wood burning appliance is to be connected to the cylinder, along with a 'conventional' boiler and Solar Thermal.

The maximum working head for the Grant DuoWave Plus Solar cylinder is 30m. Ensure that this is suitable for your installation before proceeding. If you are in doubt about the suitability of the cylinder for the system and appliances concerned then please contact the Grant Technical Helpline for assistance.

Figure 4-1 shows the installation of the DuoWave Plus 300 Indirect Solar cylinder installed as part of an open vented hot water system.

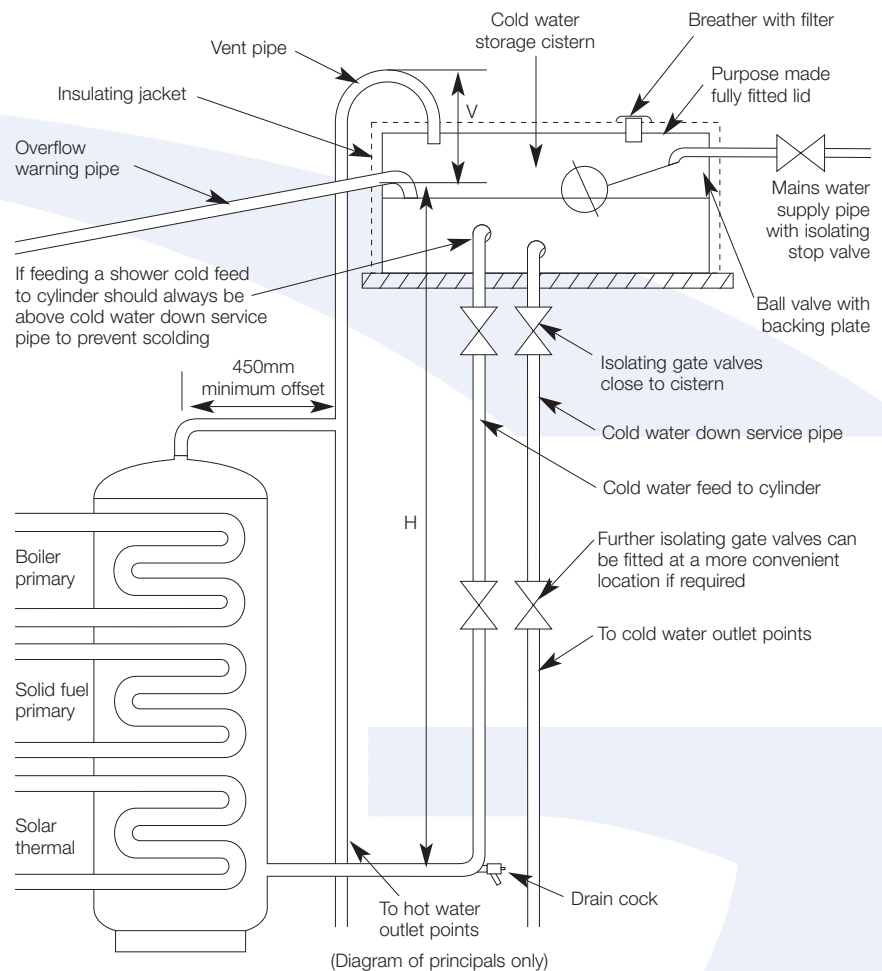

Figure4-2: Open vented cylinder

valve can be fitted in the cold water feed pipe located adjacent to the CWSC.

A Drain Cock (DC) must be fitted at the lowest point of this supply pipe adjacent to the cylinder to enable draining of the pipe and cylinder.

4.7 Open Vent Pipe

The cylinder must be installed with an Open Safety vent (OSV) pipe. This must be connected to the hot water outlet on the top of the cylinder and rise continuously to terminate over the CWSC. Refer to Figure 4-2.

There should be an 'offset' of at least 450mm in the OSV pipe to reduce the tendency for thermal circulation and loss of heat from the vent pipe. Refer to Figure 4-1.

The OSV pipe must be of an adequate diameter, the minimum pipe size being 22mm.

Important: The OSV pipe **MUST** be permanently open with **NO** obstructions (e.g. no valves fitted). The OSV pipe

and cold feed pipe should not be connected together.

Under no circumstances should the vent pipe from an open vented hot water cylinder terminate over any combined feed and expansion cistern (F&EC) connected to a primary circuit or any cistern used for the storage and distribution of wholesome water.

An OSV pipe should be insulated to protect it from freezing.

4.8 Primary Connections

The 'uncontrolled' heat source should be connected to the middle coil via the two 28mm compression connections.

The Solar Thermal primary should be connected to the bottom coil via the two 22mm compression connections, with the Boiler primary connected to the top coil 22mm compression connections.

All primary pipework should be insulated between boiler and cylinder.

4.5 Cold Water Storage Cistern (CWSC)

Cisterns should be installed in accordance with BS6700:2006 and also the relevant Water Regulations – i.e. the Water Supply (Water Fittings) Regulations 1999 or the Water Byelaws 2000, Scotland.

If the cistern is used to provide cold water to the hot water supply only, it should have a capacity at least equal to the hot water cylinder it is supplying.

4.6 Cold Feed Pipe

The cold water feed pipe from the CWSC to the cylinder should be sized in accordance with BS6700:2006. This feed pipe should not supply water to any other fitting.

Connect the cold feed pipe to the cold inlet connection of the cylinder. Refer to Figure 2-3.

A service valve (quarter turn lever operated full-bore valve) should be fitted in the feed pipe in a convenient and accessible position, e.g. adjacent to the cylinder. If required a second service

5 Electrical Installation



WARNING

This appliance **must** be earthed.

All electrical wiring must be carried out by a competent person and in accordance with the **current I.E.E. Wiring Regulations**.

The control equipment supplied will ensure that the cylinder functions safely. From an economic and convenience point of view, it is intended that these controls operate in conjunction with other control packages for example "S", or "Y" plan type systems, which incorporate a programmable time clock, etc.

5.1 Immersion Heater

All cylinders are supplied fitted with one immersion heater.

The 3kW 230V 50Hz-immersion heater should be wired in accordance with the instructions given in Figure 5-1.

The cable **must** be routed through the strain relief bush. The control thermostat is pre-set at approximately 60°C. The immersion heater conforms to EEC Directive 76/889 for radio interference and complies with EN 60335-2-73.

Installation and wiring instructions for the immersion heater are supplied with each unit. Follow the wiring instructions connecting the live, neutral and earth as indicated.

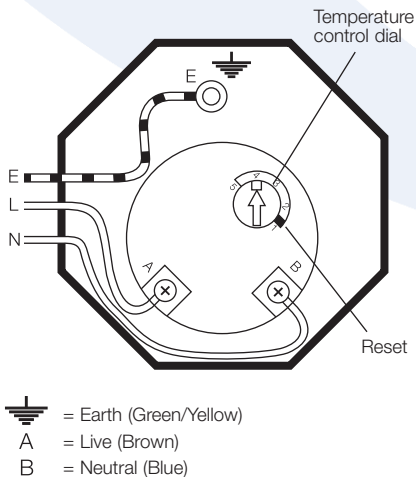

Figure 5-1: Immersion heater wiring connections

The unit must be permanently connected to the electrical supply through a double-pole isolator. A safety cut-out is also incorporated within the thermostat and is factory set to operate at $80^{\circ}\text{C} \pm 5^{\circ}\text{C}$.

IMPORTANT

Before resetting the safety cut-out or altering the thermostat setting, isolate electrical supply to the unit prior to removal of the cover. Investigate and identify the cause of the cut-out operation and rectify the fault before manually resetting the cut-out by pressing in the reset button. Ensure the cover to the immersion element is replaced correctly and the retaining nut is fitted. Finally switch the mains electricity supply back on.



WARNING

The manual re-set high limit thermostat must not under any circumstances be bypassed. This is pre-set to 80°C and to prevent nuisance tripping the control thermostat should always be left in position 4.

5.2 Immersion Heater Wiring Instructions

- Ensure the main's voltage corresponds to the voltage rating of the immersion heater as shown on the rating label on the terminal cover.
- The immersion heater is factory fitted to the cylinder. If the immersion heater needs to be replaced it must be fitted to the cylinder using the gasket provided on the unit. Use a shaped spanner, Stillsons or pipe grips should not be used. The use of sealing compound is not recommended.
- Wire the immersion heater in accordance with the wiring diagram (Figure 5-1). It should be wired through a double pole isolator switch or controller, with a minimum break capacity of 13 amp having contact separation of at least 3 mm, using 1.5mm sq. flexible cable, 85°C rubber insulated HOFRR sheathed, to comply with BS 6141 table 8 and must be fully earthed.

- The BEAB approval certification on this immersion heater only applies if a Cotherm TSE rod type thermostats is used. The temperature setting of the control thermostat should always be left in position 4.

The control thermostat has an adjustment range between 25°C and 65°C , however it is recommended that it is set to 60°C . The overheat thermostat incorporated within the dual thermostat will operate at 90°C .

5.3 'Y' Plan System Schematic and Wiring Diagram

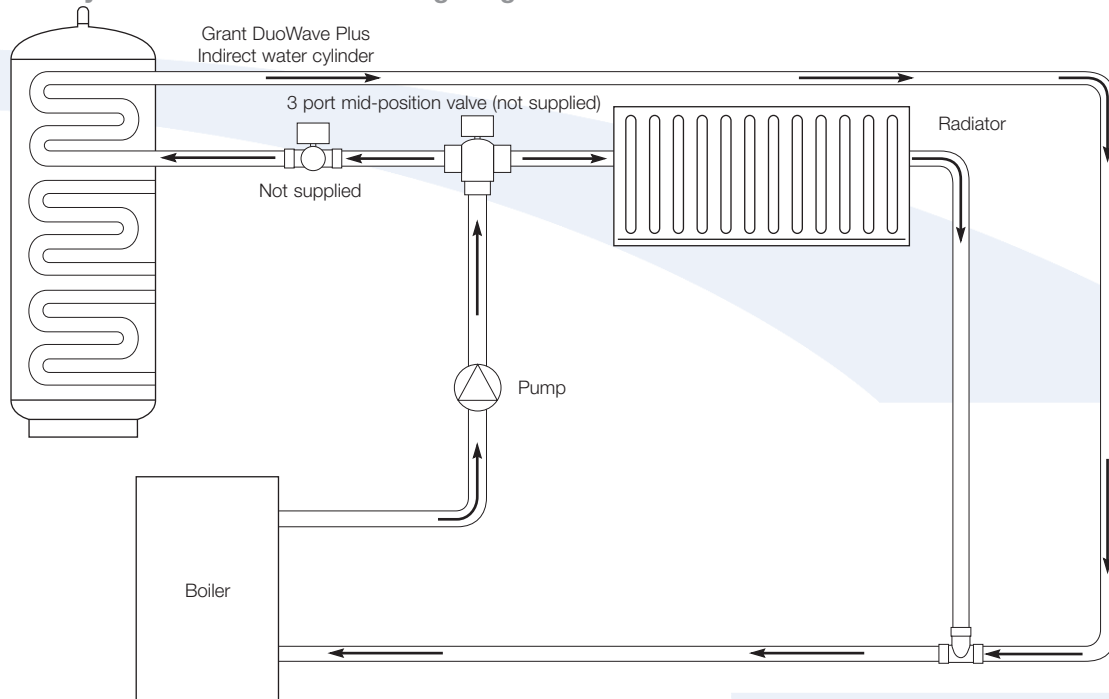

Figure 5-2: 'Y' Plan system schematic

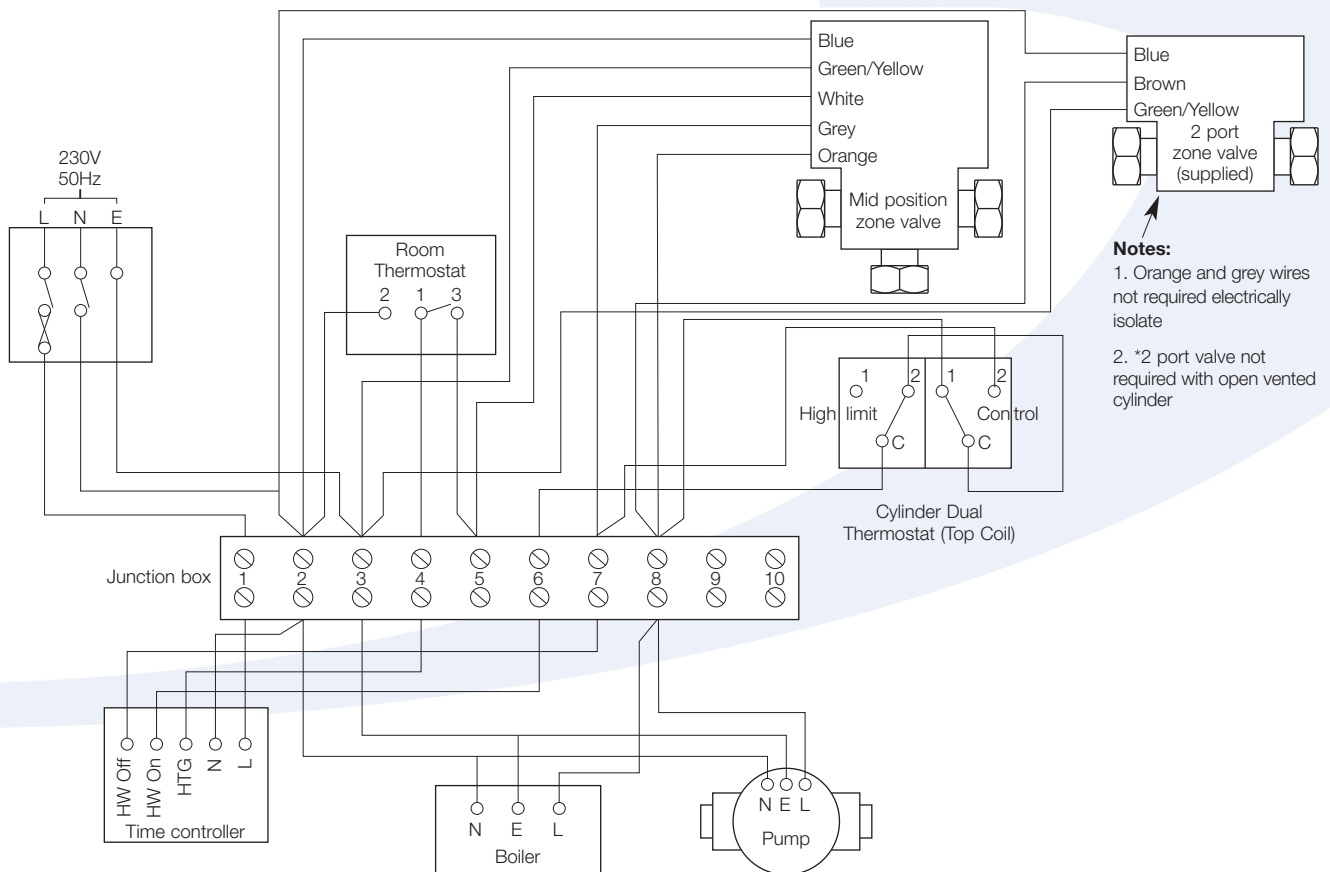

Figure 5-3: 'Y' Plan wiring layout

5 Electrical Installation

5.4 'S' Plan System Schematic and Wiring Diagram

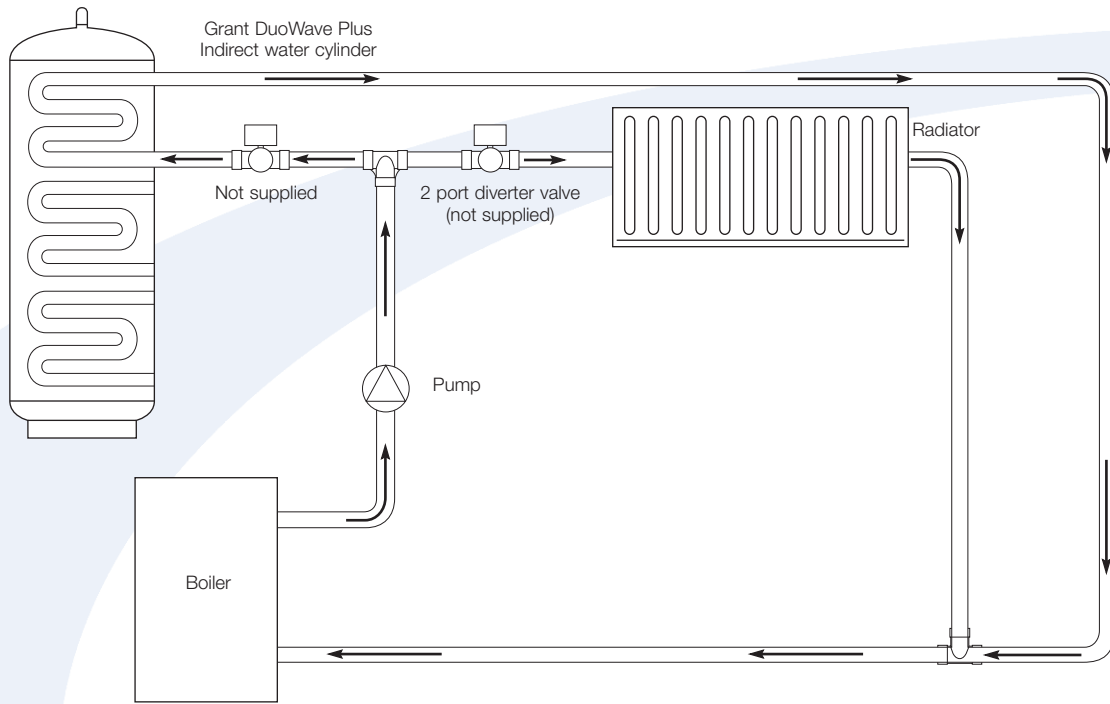

Figure 5-4: 'S' Plan system schematic

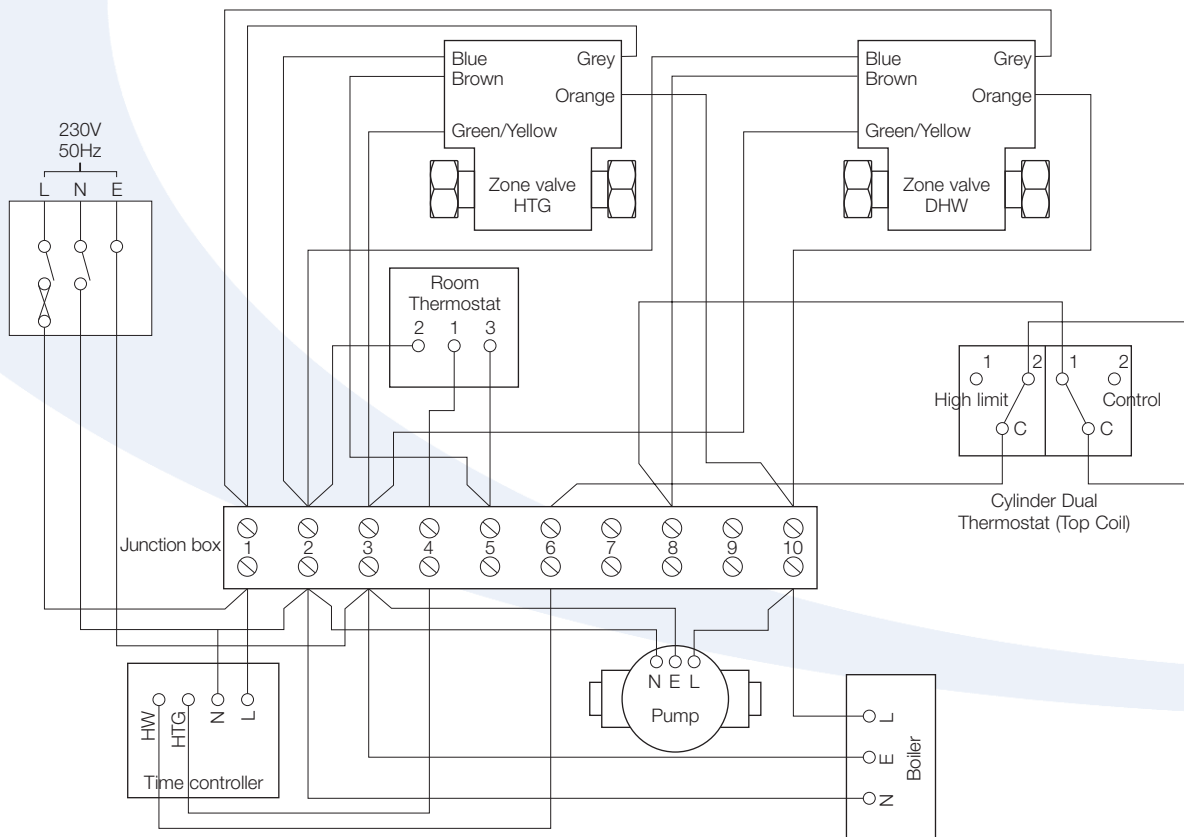

Figure 5-5: 'S' Plan wiring layout

5.5 Solar Thermal Schematic and Wiring Diagram

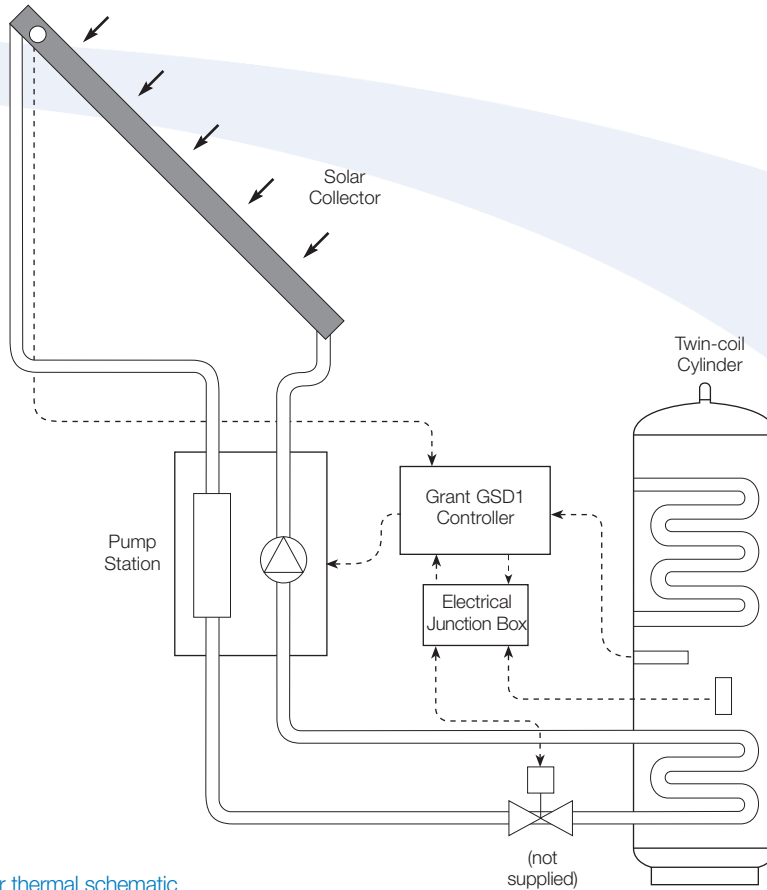

Figure 5-6: Solar thermal schematic

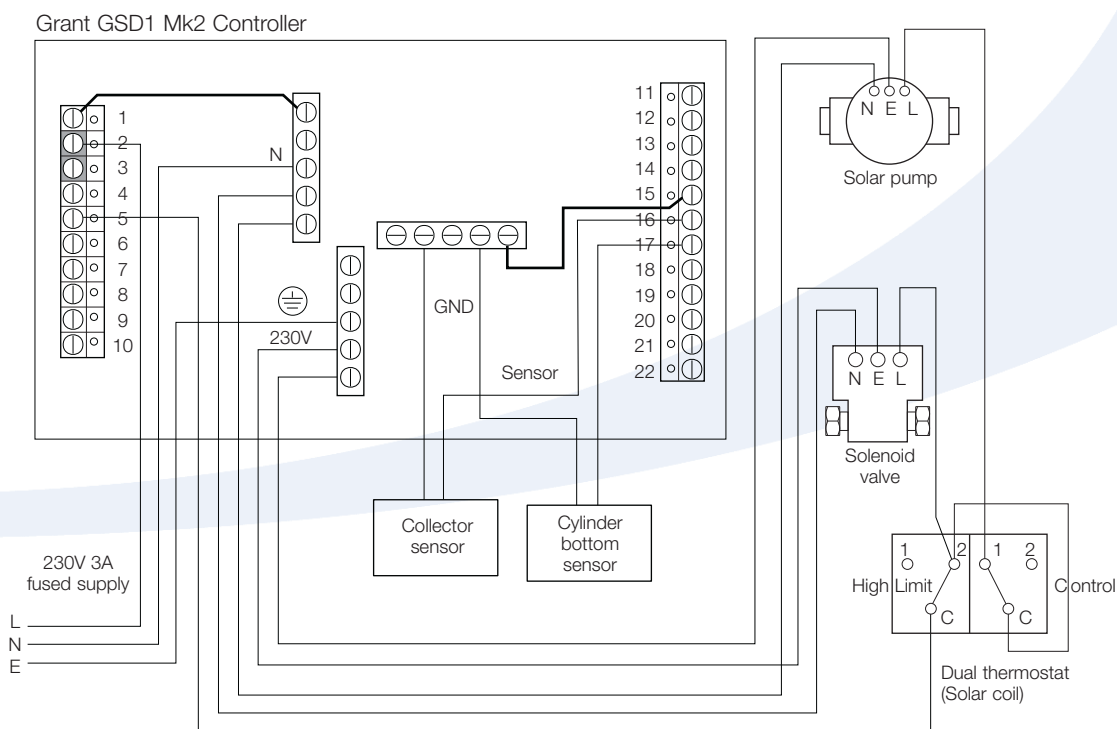

Figure 5-7: Solar thermal system typical hydraulic wiring layout

6 Commissioning, Draining Down & Safety

6.1 Filling the Cylinder

IMPORTANT

Before filling the cylinder check that the immersion heater has not loosened in transit. Tighten as necessary using a shaped spanner. Stillsons or pipe grips should **not** be used.

1. Open all hot water taps.
2. Turn on the stop cock.
3. When water flows from all taps close the taps.
4. Allow system to stabilise for five minutes.
5. Open each hot water tap in turn to expel air from the system pipe work.
6. Check for leaks.
7. Manually operate Temperature and Pressure Relief Valve (17) - Figure 2-2, to ensure free water flow through discharge pipe. (Turn knob to left).

6.2 Draining Down

Switch the electrical power off (important to avoid damage to element). Isolate boiler from DuoWave Plus unit.

Turn off the cold water supply valve (stop cock). Open hot water taps. Open drain (21) - Figure 2-2. The unit will drain.

6.3 Safety Cut-Out

1. The safety cut-out operates if:
 - a. Wiring is incorrect.
 - b. The immersion heater thermostat or cylinder thermostat fails.
 - c. Thermostat is set too high.
2. Remember before resetting the safety cut-out or altering the thermostat setting, isolate electrical supply to the unit prior to removal of the electrical box lid.
3. Reduce thermostat setting and press the reset button. After adjustments are completed, ensure the lid to the electrical box is replaced correctly and the retaining screw is fitted.
4. If the problem persists, please contact your installer in the first instance.

6.4 Hot Water Discharge from Tundish

There are three reasons why hot water will discharge from the tundish:

1. Thermal cut-out has malfunctioned.
2. The control thermostat has malfunctioned.
3. The T & P valve is letting by.

In all cases, should a repair be necessary, the work must be carried out by a competent person.

Isolate the cylinder from all electrical supplies before commencing maintenance work.

6.5 Customer Handover

1. Explain the operation of the system to the User, referring to Section 10 of these instructions.
2. In particular, make the User aware of what to do if water is seen to flow from either the T&P Valve. Refer User to the Information given in Section 10.

7 Maintenance

7.1 Servicing and Maintenance

1. Servicing and maintenance must only be carried out by a competent hot water installer, or by Grant Engineering (IRL) Ltd authorised personnel.
2. Before any work whatsoever is carried out on the installation, it MUST first be isolated from the main's electricity supply.



Both the primary and secondary systems will contain very hot water that will scald; therefore care should be taken when opening any joints, seals or valves.

3. Only use spare parts authorised by Grant Engineering (IRL) Ltd. The use of unauthorised spare parts will invalidate the warranty.
4. Drain the cylinder – When draining the cylinder, always switch off the boiler and the immersion heater first. Turn off the water supply at the mains stopcock.

Connect a hose pipe to the drain cock (see Figure 2-2) and route it to a convenient gully. Open the drain cock and all hot taps that are served by the cylinder. The cylinder may take several minutes to empty completely.
5. In hard water areas it may be necessary from time to time to remove and de-scale the immersion heater element. Replace the gasket each time it is removed.

6. Whilst the hose pipe is connected, the drain cock open and with the immersion heater removed, the cylinder may be flushed out to remove any debris, sand or lime scale particles that may have collected in the bottom by using a further hose pipe connected to the cold water main.
7. Close the drain cock, disconnect the hose, refit the immersion heater and close all hot water taps before reopening the stopcock. Allow the cylinder time to fill whilst checking for any leaks. Release any air from the system by opening each hot water tap individually, starting with the one furthest from the cylinder.
8. Manually lift the expansion relief and temperature, every 12 months (more frequently in hard water areas) to prevent debris from building up behind the valve seat. Whilst carrying out this operation, check that the discharge to waste is unobstructed. Check that each valve seals correctly when released. As the valves are pre-calibrated, they require no further maintenance.
9. Finally switch on the mains electricity supply to the immersion heater and the boiler. As the system heats up, check again for any leaks and rectify as necessary.

8 Fault Finding Guide

8.1 Intermittent Water Discharge

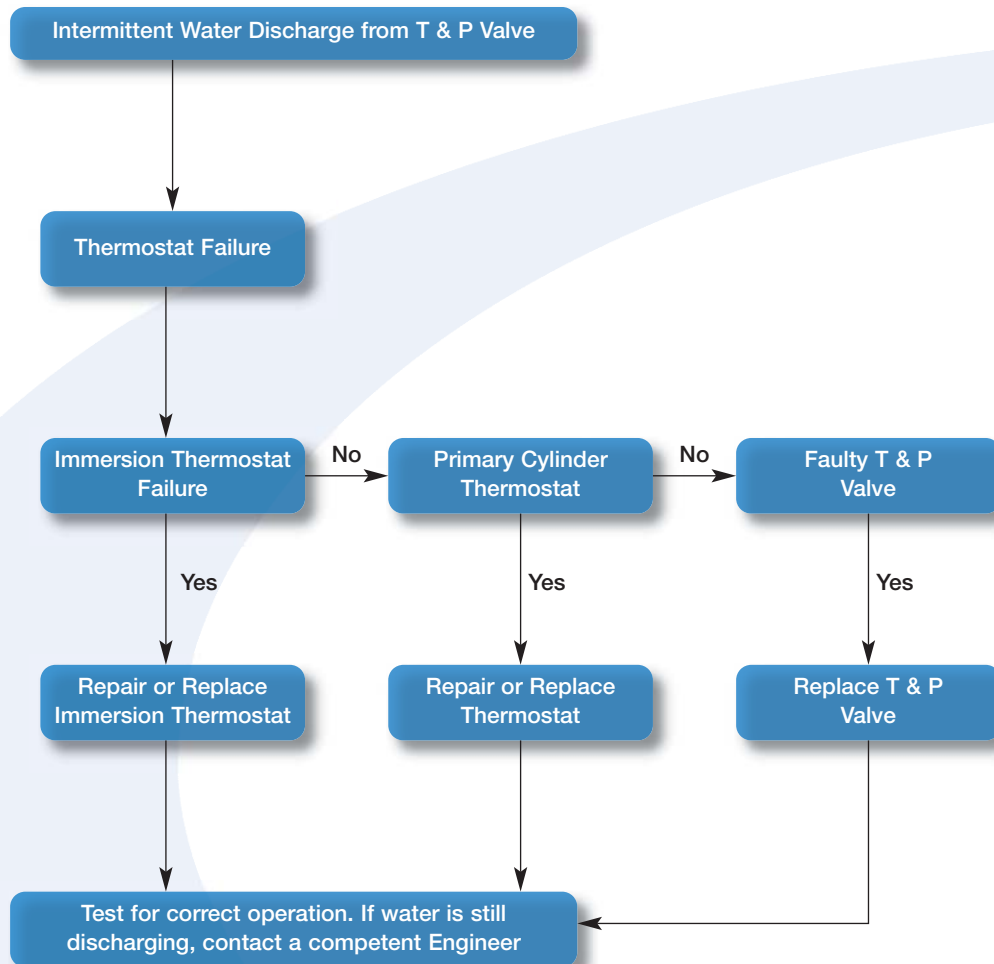

8.2 Constant Water Discharge

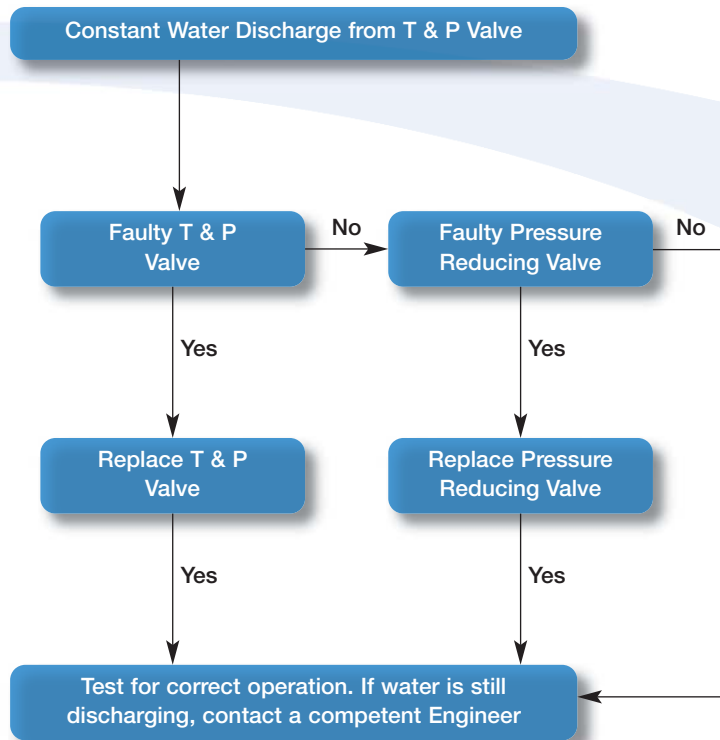

8 Fault Finding Guide

8.3 No Flow from Hot Water Taps

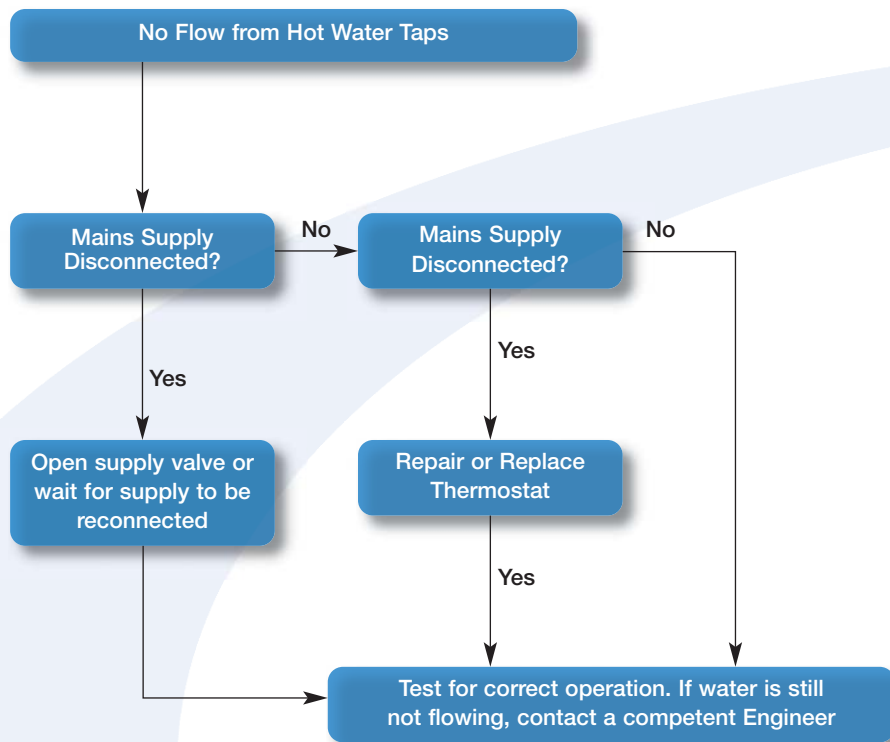

8.4 Cold Water Flow from Hot Water Taps

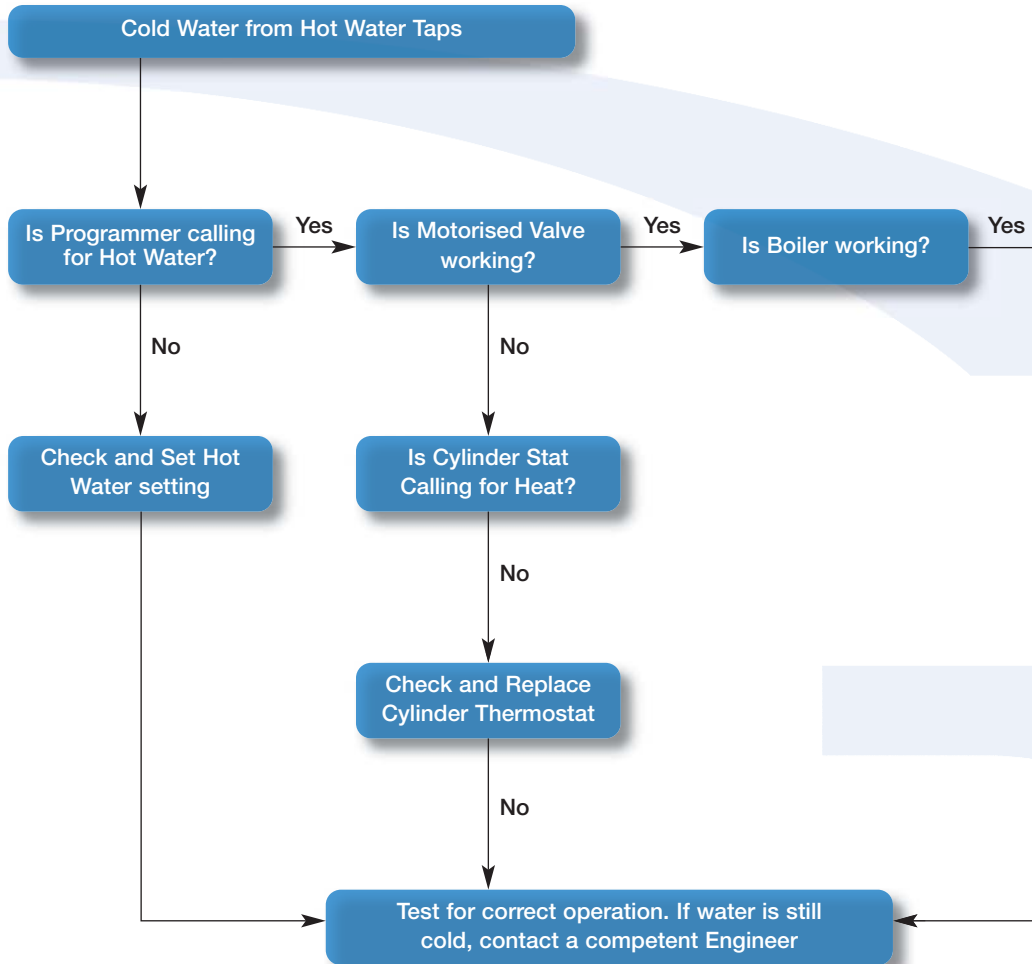

8 Fault Finding Guide

8.5 Excessive Hot Water from Taps

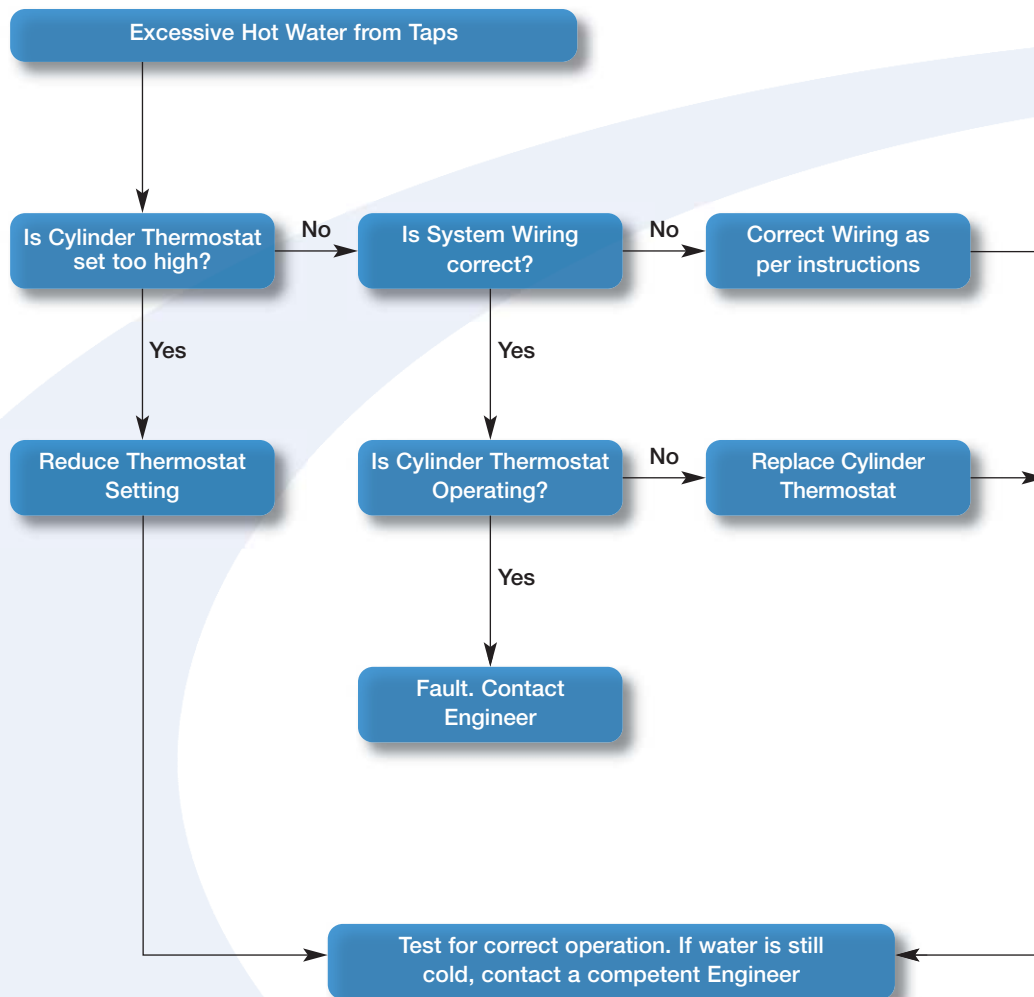

9 User Instructions

9.1 User Instructions

1. Your Grant DuoWave Plus Solar vented hot water cylinder has been designed to give many years of trouble-free service and is made from hygienic high grade stainless steel. All models include a 3 kW electric immersion heaters for times when your central heating is switched off, during the summer for instance.
2. The flow temperature of the hot water can be set to your requirements on the immersion heater up to 60°C and the indirect system dual thermostat up to 65°C. These temperatures should not be set any higher otherwise nuisance tripping of the high limit thermostat will occur. If you are in any doubt, these adjustments should be best left to a qualified electrician.
3. When you first fill a basin the water may sometimes appear milky. This is due to very tiny air bubbles in the water, which will clear very quickly.

WARNING

If water is seen to flow from the Temperature & Pressure Relief (T&P Valve) valve on the cylinder seek expert advice immediately.

If the water is flowing from the T&P Valve, immediately:

Shut off the electrical supply to the immersion heater(s)

Shut down the boiler

Switch off ALL other heat sources to the cylinder e.g. solar, etc.

DO NOT SHUT OFF THE WATER SUPPLY TO THE CYLINDER.

Contact your installer to check the system.

IMPORTANT

Do NOT tamper with any of the Safety controls fitted to the cylinder. If you suspect a fault always contact a **COMPETENT** installer who is **QUALIFIED** to work on water cylinders.

10 Warranty

10.1 The Grant Cylinder Warranty

Dear Customer

You are now the proud owner of a Grant Cylinder from Grant Engineering (IRL) Ltd, which has been designed to give you years of reliable, trouble free operation.

Grant Engineering (IRL) Ltd guarantees all electrical and mechanical components supplied with the cylinder for a period of one year from the date of purchase. In addition, the stainless steel used in the manufacture of the cylinder is guaranteed for a period of twenty five years with the manufacturing process of the cylinder guaranteed for one year from the date of purchase, provided that the cylinder is installed in full accordance with the installation instructions provided and the system is serviced after twelve months operation. (see Terms and Conditions).

Breakdown during the Manufacturer's Warranty

If your Grant Cylinder should fail during the first year, you must contact Grant Engineering (IRL) Ltd, who will arrange for the repair under the terms of their Warranty, providing that the system has been correctly installed and commissioned, and the fault is not due to misuse, or the failure of any external components not supplied by Grant IRL Ltd (e.g. pipework, etc.).

In the first Instance:

Contact your installer or commissioning engineer to ensure that the fault does not lie with the system or any other components, or any incorrect setting of the system controls.

If a Fault is Found:

Ask your installer to contact Grant Engineering (IRL) Ltd, Service Department on 057 9120089 who will arrange for a qualified service engineer to attend to the fault.

Free of Charge Repairs:

During the first year no charge for parts or labour will be made providing that the Cylinder has been installed and commissioned correctly in accordance with the manufacturer's instructions and serviced at twelve month intervals. Proof of 'purchase' date must be provided upon request.

Chargeable Repairs:

A charge will be made if the cause of the breakdown is due to any of the following:

- **Faults caused by the plumbing or heating system, external electrics and external components.**
- **The Grant Cylinder has not been commissioned, or serviced in accordance with the installation and servicing manual.**
- **The system has been installed for over one year.**

Terms of Manufacturer's Guarantee

1. The Grant Cylinder guarantee starts from the date of purchase.
2. All electrical and mechanical components supplied with the Grant Cylinder are guaranteed for a period of one year. The stainless steel used in the manufacture of the cylinder is guaranteed for a period of twenty five years with the manufacturing process of the cylinder guaranteed for one year.
4. The Grant Cylinder must be installed by a competent/licensed installer and in accordance with the Codes of Practice and Regulations in force at the time of the installation.
5. The Grant Cylinder and its components must not have been modified or tampered with.
6. The installation must be serviced every twelve months as per the installation instructions. (Receipts should be kept as proof).

7. The Grant Cylinder must be connected to a mains water supply (installations utilising a private water supply are not covered by this guarantee).

8. Breakdown/failure due to lime-scale will not be covered by this guarantee.
9. The Grant Cylinder must not be sited in a location where it may be subjected to frost.
10. All claims under this guarantee must be made to Grant Engineering (IRL) Ltd prior to any work being undertaken. Proof of purchase and date of installation must be provided on request. Invoices for call out/repair work by any third party will not be accepted unless previously authorised by Grant Engineering (IRL) Ltd.
11. This guarantee is transferable providing the installation is serviced prior to the dwelling's new owners taking up residence. Grant Engineering (IRL) Ltd must be informed of the new owner's details.
12. Grant Engineering (IRL) Ltd will endeavour to provide prompt service in the unlikely event of a problem occurring, but cannot be held responsible for any consequence of delay however caused.
13. This guarantee applies to Grant Cylinders installed in the Republic of Ireland and Northern Ireland. Provision of in-warranty cover elsewhere is subject to agreement with Grant Engineering (IRL) Ltd.



Notes



GRANT ENGINEERING (IRELAND) LTD

Crinkle, Birr, Co. Offaly, Ireland

Tel: (057) 91 20089 Fax: (057) 91 21060 Email: info@grantengineering.ie www.grantengineering.ie

This manual is accurate at the date of printing but will be superseded and should be disregarded if specifications and/or appearances are changed in the interests of continued product improvement.
All goods sold are subject to our official Conditions of Sale, a copy of which may be obtained on application. © Grant Engineering (Ireland) Limited 2008. No part of this manual may be reproduced by any means without prior written consent.